

# Mimic

MARK GILLESPIE (2018)

Based on Jon Moran's  
*Treasure Chest*

## NOTATION

-  Colored side
-  Light side

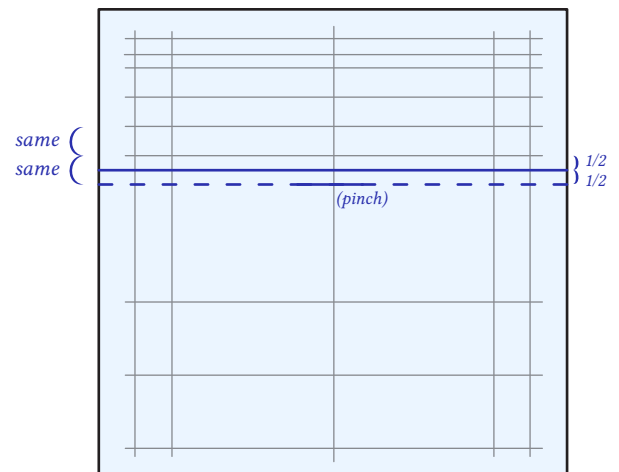
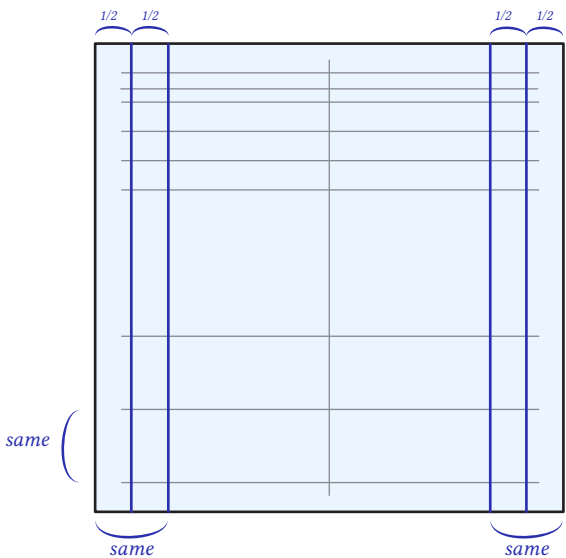
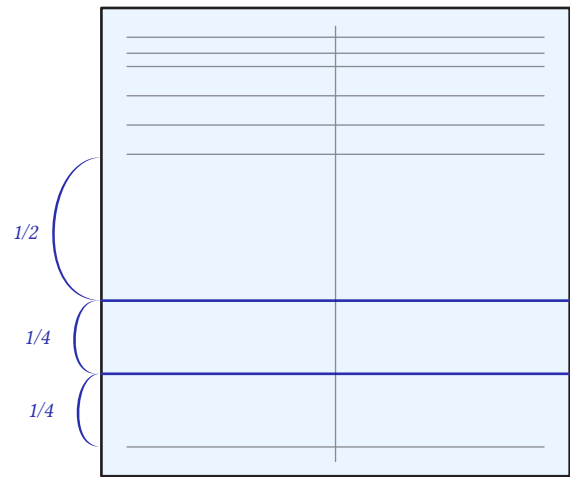
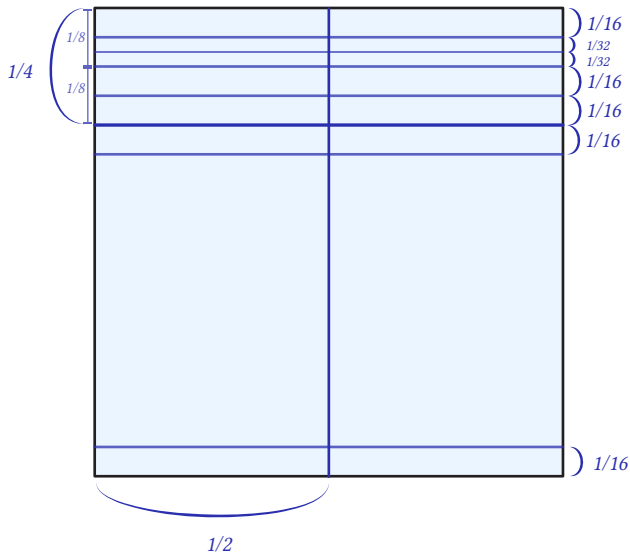
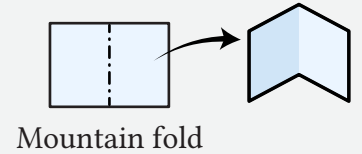
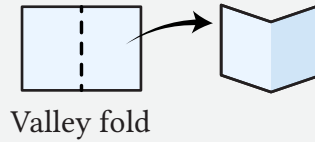

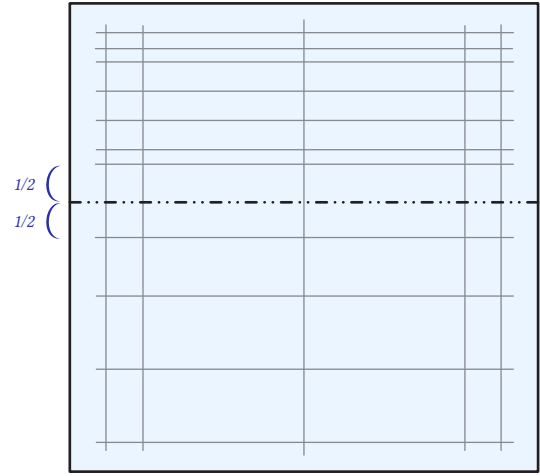
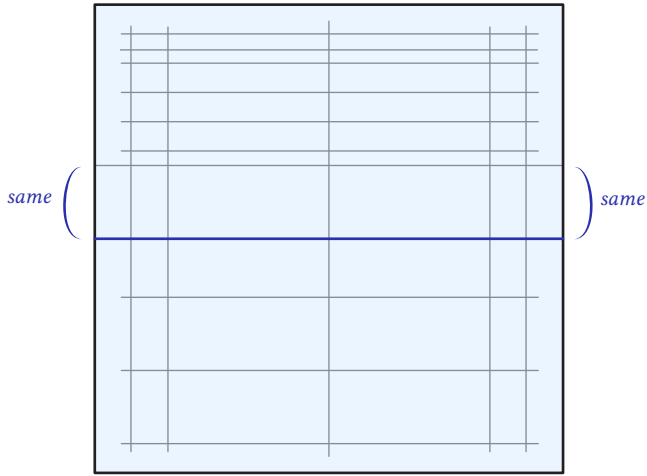

*same*
*same*  
 Almost, but not exactly,  
 half way up the paper

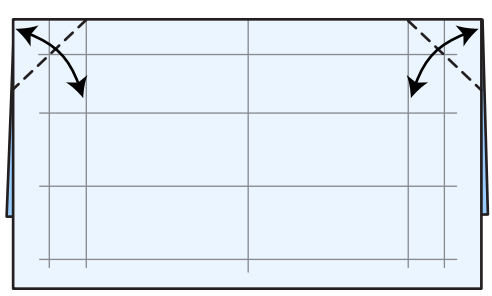

Petal fold

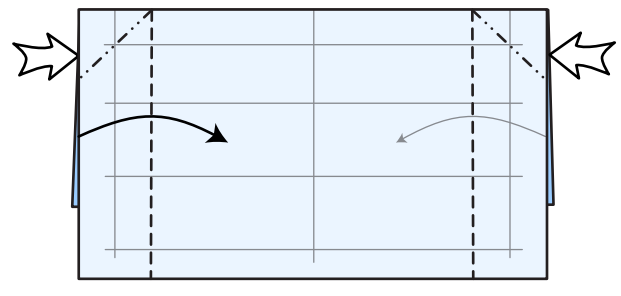

Squash fold

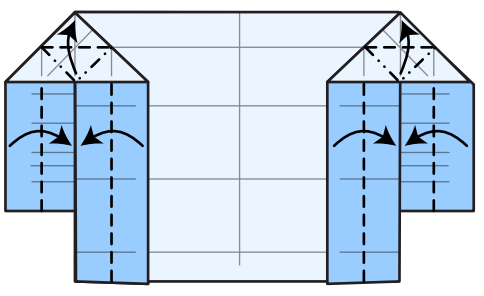

Petal fold

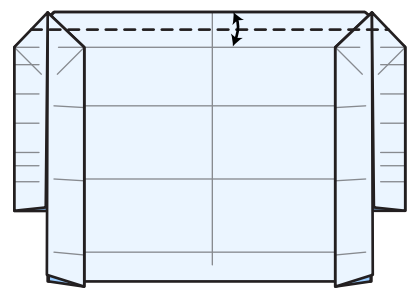

Fold and unfold

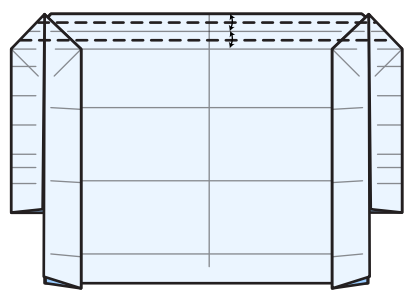

Fold and unfold

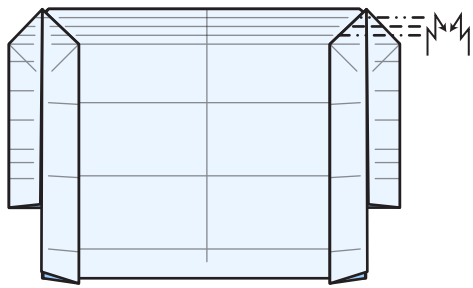

Box pleat

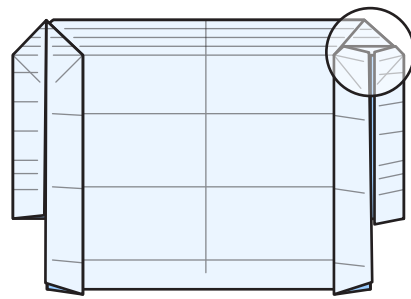

Completed box pleat. Repeat on left

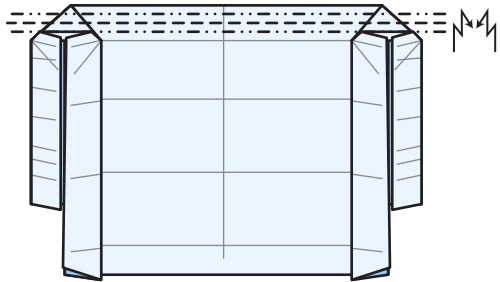
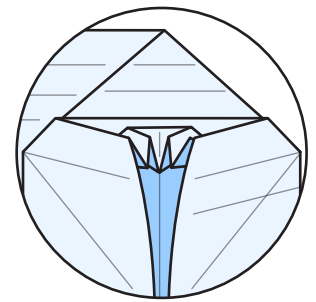

Box pleat

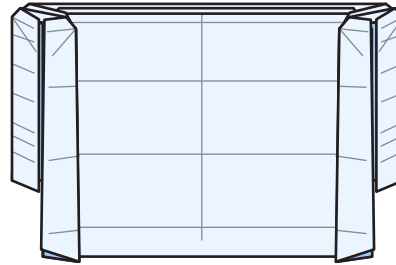

Completed box pleat.  
Unfold everything

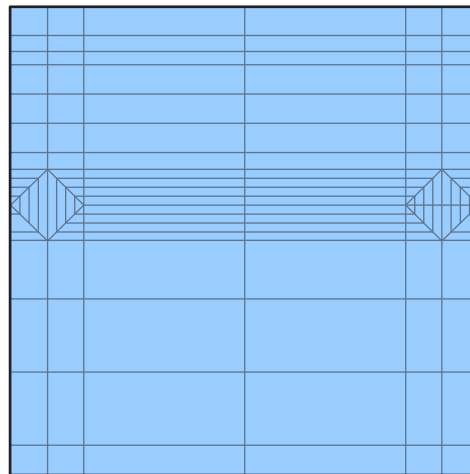

Unfolded model

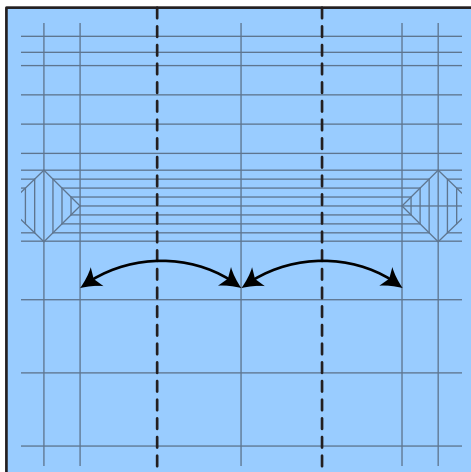

Fold and unfold  
(fold is almost, but not quite, sixths)

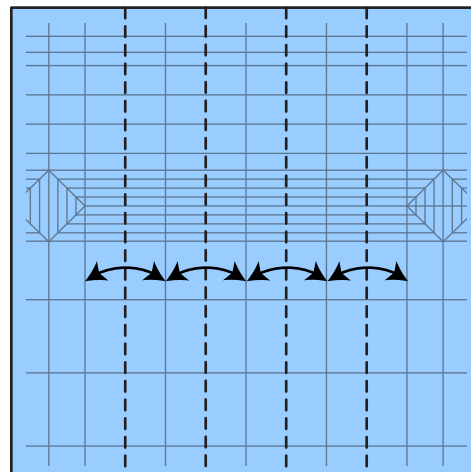

Fold and unfold

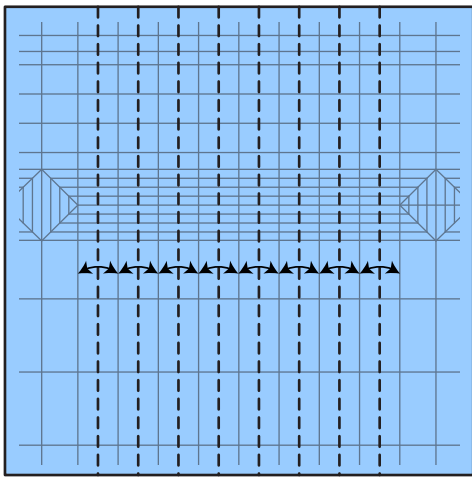

Fold and unfold

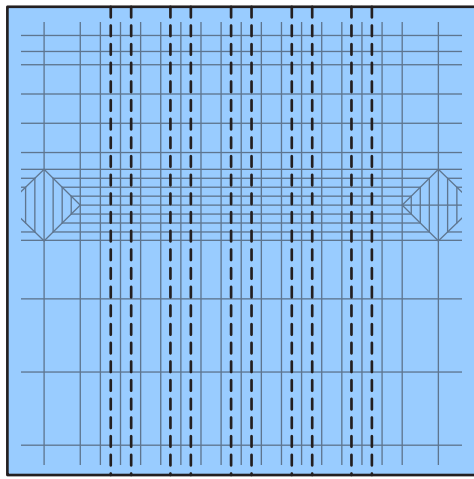

Fold and unfold

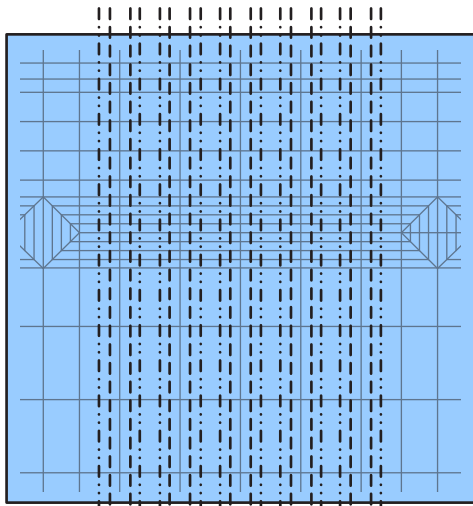

Pleat

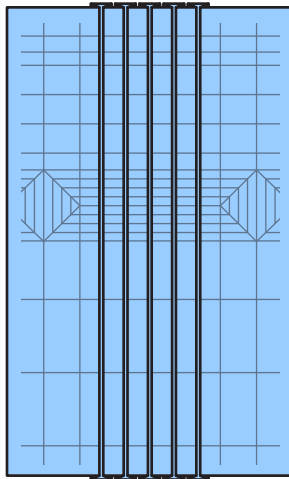

Flip over

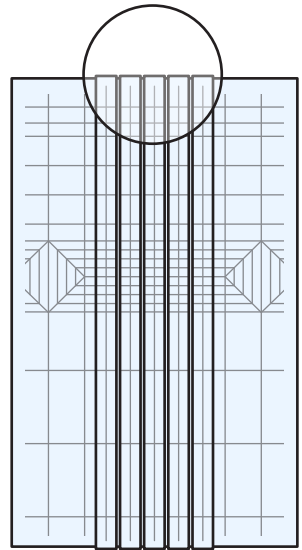

Next step is zoomed in

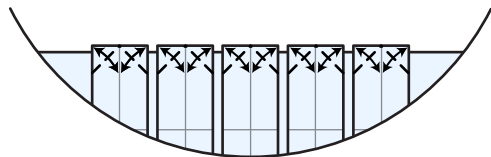

Fold and unfold

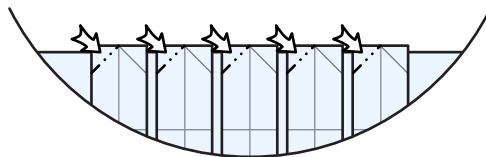

Reverse fold

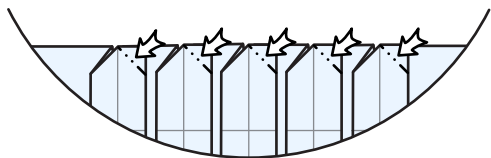

Reverse fold

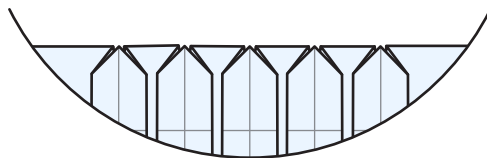

Flip over

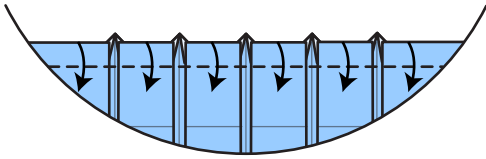

Fold flaps down as far as they will go

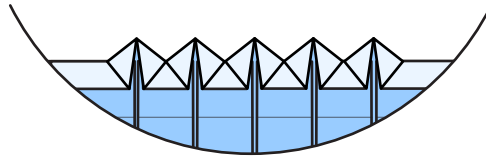

Completed fold

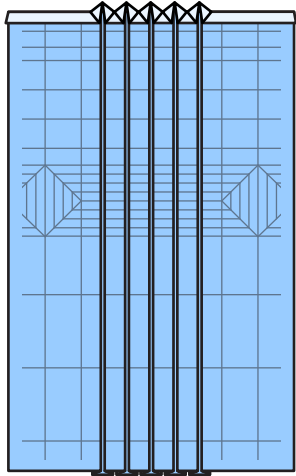

Repeat on bottom

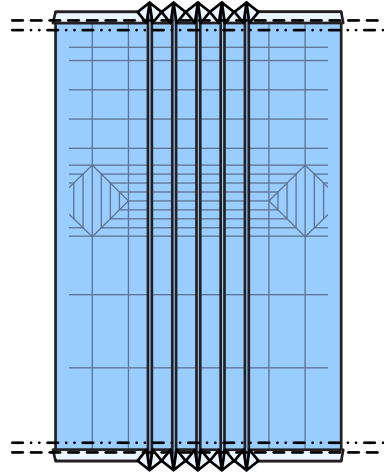

Pleat. The fold will overlap the white flaps slightly

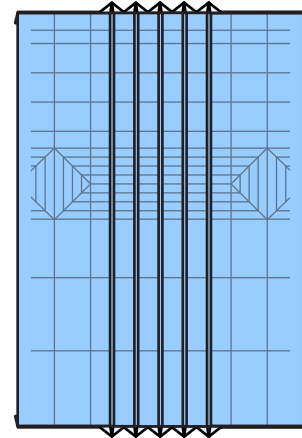

Flip over

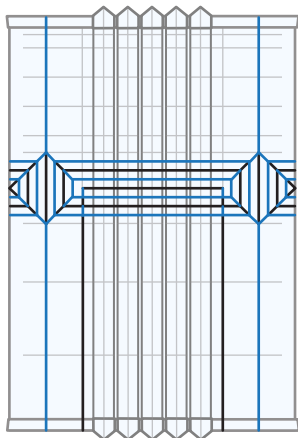

Refold the box pleat we made earlier. For this step, mountain folds are colored blue and valley folds are colored black

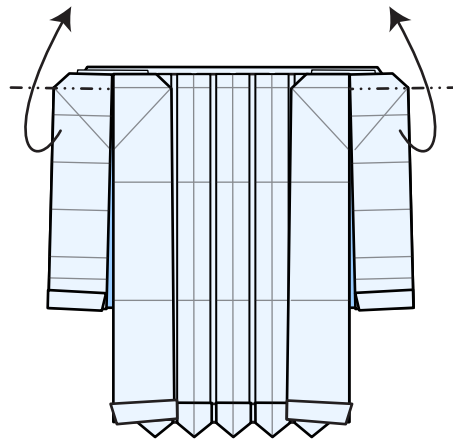

Fold back flap up

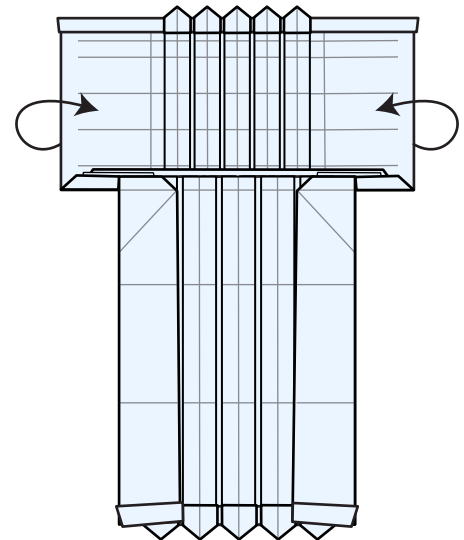

Flip pocket around (This is tricky and involves some unfolding/refolding)

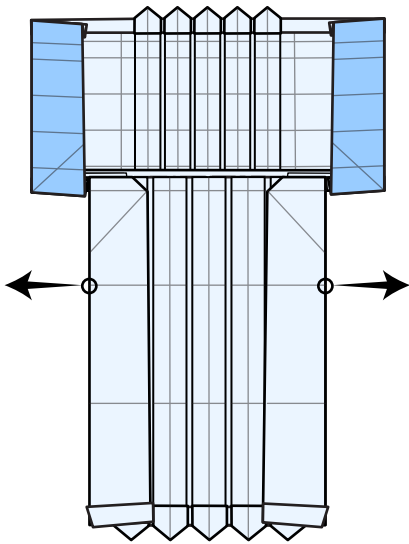

Open up side flaps.  
Model will not lie flat

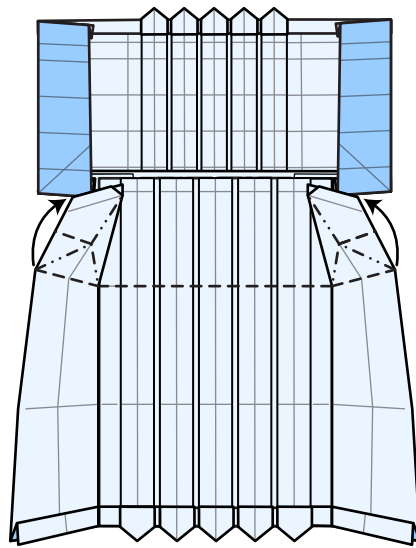

Fold bottom forwards  
while making rabbit ear folds  
on the sides

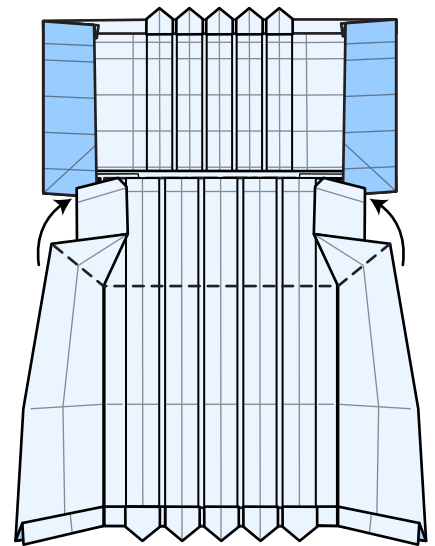

fold in progress

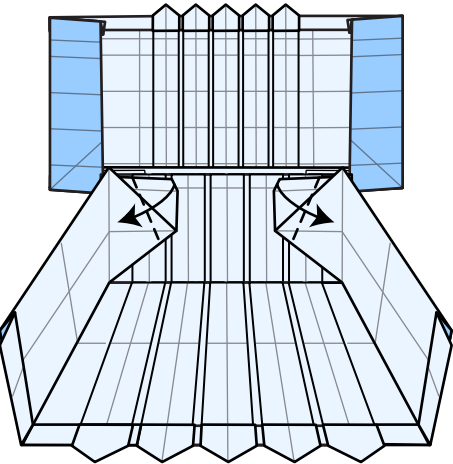

Fold flaps down to lock in crease

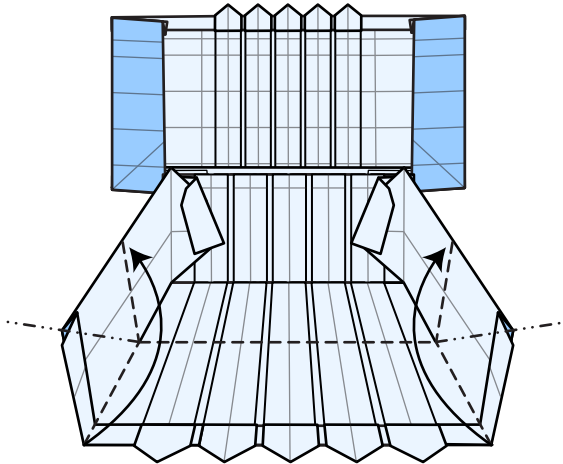

Collapse front of box

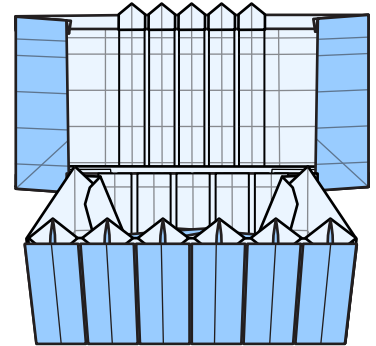

Finished collapse

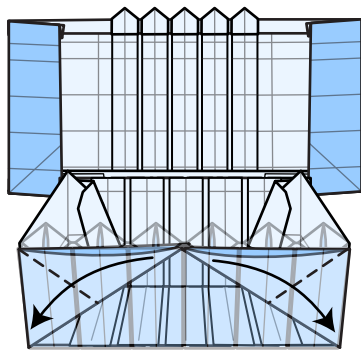

*(x-ray view through front)*  
Fold down flaps to  
lock in collapse

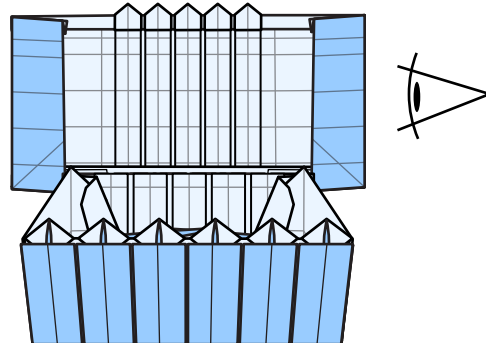

Fold sides of lid forwards to lie  
parallel with sides of body.  
Next steps will be drawn in  
side view

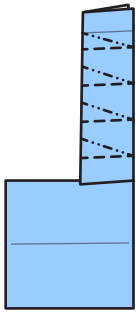

Pleat

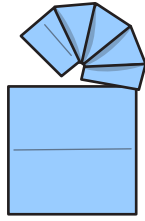

Completed pleat.  
Note that the segments  
form triangles which all  
meet at a center point

Unfold pleat

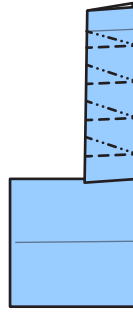

Open up flap slightly to  
crimp along the creases  
you just made. This crimp  
holds the creases in place



Fold in corners  
to straighten out  
edge of lid

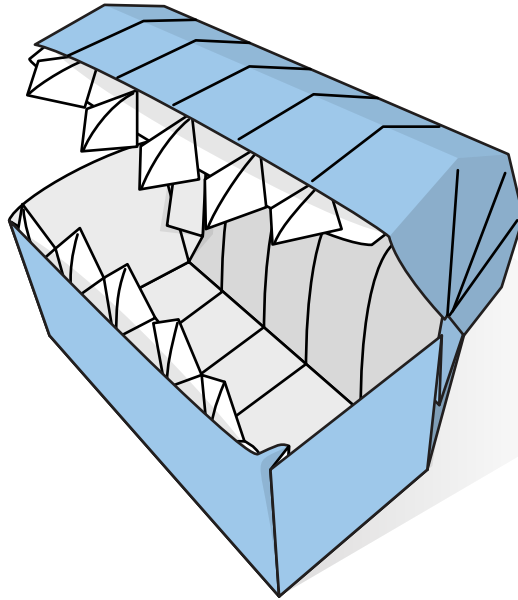

Done!